

COMMERCIAL/INDUSTRIAL HIGH PRESSURE REGULATORS



TYPE 630



TYPE 627*

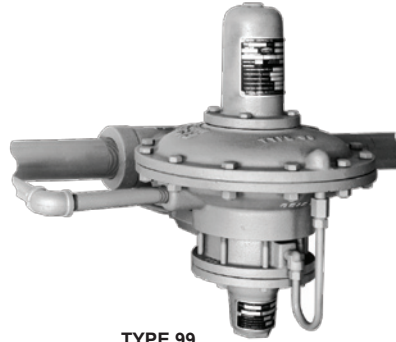

TYPE 99



TYPE 1301F

For Commercial and Industrial high-pressure applications, like factories, office building, restaurants, etc. Emerson has a wide variety of products and solutions. For ease of reference, only the most popular commercial and industrial regulators are shown on this page. Other orifice sizes, body sizes and outlet pressure ranges are available. The higher capacities on commercial and industrial installations usually require a Two-Stage regulator system.

Note: Because of various spring ranges and orifice sizes, all commercial and industrial regulators should be individually sized for the particular installation. Consult specific product bulletins for maximum pressure ratings. Contact your local LP-Gas Regulators and Equipment Distributor for assistance.

Types 627 and 630 – Large capacity direct-operated high pressure regulators designed for loads up to 10 700 000 and 14 000 000 BTU/hr (120 and 157 SCMh) respectively. The Types 627 and 630 are normally used in conjunction with Type S302G or S202G units, however, they can also be used on Final-Stage (pounds to pounds) service. A Type 1805 relief valve is recommended to prevent excessive build-up in the downstream line. The diaphragm case and body of the

Type 627 can be rotated in four positions to allow easy installation. Additional configurations of the Type 627 with internal relief and control line connections for monitor systems are available. For both the Types 630 and 627, additional pressure ranges and orifice sizes are available.

Type 99 – Pilot-operated unit keeps outlet pressure constant despite varying flow rates and inlet pressures. Designed to handle loads up to 74 318 000 (837 SCMh), the Type 99 is ideal for multiple customer installations. The unique pilot design, with fast opening and closing operation, makes the Type 99 ideal for large industrial boiler applications. The Type 99 can be used for low or high pressure. A downstream control line is required.

Type 1301F – The proven reliability and accurate regulation of the Type 1301F regulator makes it ideal for numerous high-pressure drop applications. This multi-purpose regulator can be used as pilot supply or pressure-loading regulators where high-pressure operating medium must be reduced for use by gas regulator pilots or pressure-loaded regulators.

High Pressure Commercial/Industrial Regulators						
TYPE NUMBER	CAPACITIES IN BTU/hr (SCMH) PROPANE	ORIFICE SIZE, INCHES (mm)	INLET AND OUTLET CONNECTIONS	OUTLET PRESSURE RANGE, PSIG (bar)	OUTLET PRESSURE SETTING, PSIG (bar)	MAXIMUM OPERATING INLET PRESSURE, PSIG (bar)
627-5810	6 080 000 (68,44) ⁽¹⁾	3/8 (9,5)	3/4-inch FNPT	5 to 20 (0,34 to 1,4)	10 (0,69)	250 (17,2)
627-6210	10 755 000 (121) ⁽¹⁾					
627-7710	10 773 000 (121) ⁽¹⁾					
630-104/78	14 000 000 (158) ⁽¹⁾	1/2 (13)	1-inch FNPT	8 to 20 (0,55 to 1,4)		
99-510P	29 400 000 (331) ⁽²⁾	7/8 (22)	2-inch FNPT	0,25 to 2 (0,02 to 0,14)	1 (0,07)	
99-511P	33 206 000 (374) ⁽²⁾			1 to 5 (0,07 to 0,34)	5 (0,34)	
99-513P	36 368 000 (409) ⁽²⁾			2 to 10 (0,14 to 0,69)	10 (0,69)	
99-512P	37 950 000 (427) ⁽²⁾			5 to 15 (0,34 to 1,0)	15 (1,0)	
99-515P	41 112 000 (463) ⁽²⁾			10 to 20 (0,69 to 1,4)	20 (1,4)	
99-903P	44 275 000 (498) ⁽²⁾			10 to 65 (0,69 to 4,5)	30 (2,1)	
99-502PH	50 600 000 (570) ⁽²⁾			1-1/8 (29)	2-inch FNPT	1 to 5 (0,07 to 0,34)
99-503PH	61 668 000 (694) ⁽²⁾	2 to 10 (0,14 to 0,69)	10 (0,69)			
99-504PH	63 250 000 (712) ⁽²⁾	5 to 15 (0,34 to 1,0)	15 (1,0)			
99-505PH	67 993 000 (765) ⁽²⁾	10 to 20 (0,69 to 1,4)	20 (1,4)			
99-901PH	74 318 000 (837) ⁽²⁾	10 to 65 (0,69 to 4,5)	30 (2,1)			
1301F-1	3 862 564 (43,48) ⁽³⁾	5/64 (2,0)	1/4-inch FNPT	10 to 75 (0,69 to 5,2)	75 (5,2)	6000 (414)

1. Capacity based on inlet pressure 20 psig (1,4 bar) greater than outlet pressure, Internal registration, and 20% droop.
 2. Capacity based on inlet pressure 20 psig (1,4 bar) greater than outlet pressure, External registration, and 20% droop.
 3. Capacity based on 2000 psig (138 bar) inlet pressure and 10% droop.
 NOTE: Additional spring ranges and body styles are available. Ask your local distributor for more information.

*The Type 627 configurations listed above are UL listed. For additional configurations, please contact your local distributor for more information.